

DECLARATION OF CONFORMITY

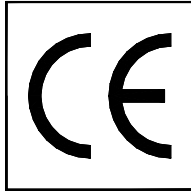

KOLVER S.r.l.
Via Marco Corner, 19
36016 THIENE (VI) ITALIA

Declare that the new tool here described:

Electric screwdriver:

FAB10RE/FR

Is in conformity with the following standards and other normative documents :

89/392/CEE and following amendments

73/23 and 93/68

EN 50144-1 and EN 602004-1

It is also in conformity with RoHS normative.

Name: Giovanni Colasante

Position: Managing Director

Thiene, 01/01/2007

Giovanni Colasante
KOLVER S.r.l.



Operator's Handbook

IDENTIFICATION DATA OF THE MANUFACTURER

KOLVER S.r.l.
VIA MARCO CORNER, 19
36016 THIENE (VI) ITALIA
TEL +39 0445 371068
www.kolver.it

IDENTIFICATION DATA OF THE PRODUCT

ELECTRIC SCREWDRIVER MODEL: FAB10RE/FR
CODE: 110010/FR
YEAR OF COSTRUCTION: 2007

THECNICAL DATA OF THE PRODUCT

TENSION : 30V DC
POWER: 30W
SPEED: 1000 RPM
TORQUE RANGE: 0,05 – 0,8 Nm

GENERAL SAFETY RULES

WARNING: when using electric screwdrivers, basic safety precaution should always be followed to reduce the risk of fire, electric shock and personal injury. Read all the instructions below before using the screwdriver and save them.

1. **Keep the work area clean and well lit.**
2. **Do not use the electric screwdrivers in damp or wet locations or in presence of flammable liquid or gases.**
3. **Avoid body contact with grounder surface as pipes, radiator, refrigerators, etc.**
4. **Keep children and visitors away from work area.**
5. **When not in use screwdrivers should be stored in dry and locked-up place and out of the reach of children.**
6. **Do not use the screwdrivers for purposes or work not intended.**
7. **Dress properly. Do not wear loose clothing and jewelry. Wear protective hair covering to contain long hair.**
8. **Never carry the screwdriver by cable or yank it to disconnect it from socket.**
9. **Use clamps or a vice to hold work.**
10. **Keep proper footing and balance at all times.**
11. **Inspect tool cable periodically and, if damaged, have it repaired or replaced by authorized service facility. Always keep handles dry, clean and free from oil and grease.**
12. **Disconnect tools from power supply before any operation of servicing, when changing accessories and when you do not use them.**
13. **When screwdriver is used outdoors, only operate with extension cords intended for use outdoors and so marked.**
14. **Pay attention while working. Do not operate screwdriver when you are tired.**
15. **Always check the screwdriver is not damaged before using it. Detective switches must be replaced by authorized service center. Never use tools that cannot be turned on or off by the switch .**
16. **The use of any other accessory other than recommended in this operating instruction may represent a risk of personal injury.**
17. **Have the screwdriver repaired only by authorized and expert people. Failing to do so may represent a serious danger.**

WARNING: before connecting the control unit and power supply to the socket, please check the voltage you are using is that indicated on the label of the unit itself.

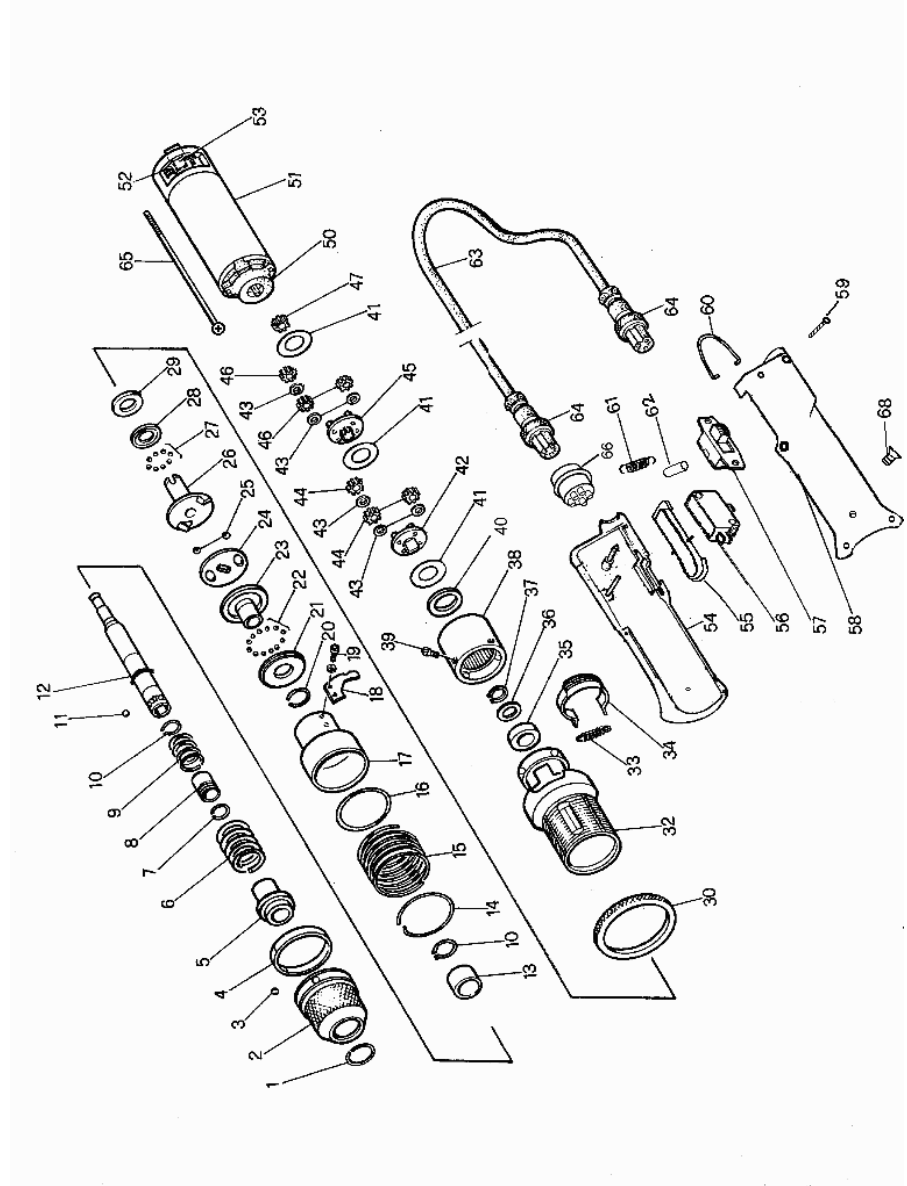

SPARE PARTS LIST FAB10RE/FR

REF	DESCRIPTION	CODE	REF	DESCRIPTION	CODE
1	Stop Ring	200001	34	Micro Switch	200034
2	Torque Nut	211002	35	Bearing	200035
3	Steel Ball	200003	36	Spacer	200036
4	Circlip	200004	37	Circlip	200037
5	Bushing	200005	38	Inner Gear	210038
6	Torque Spring	210406	39	Screw	200039
7	Circlip	200007	40	Circlip	210040
8	Bit Ring	200008	41	Washer	200041
9	Bit Spring	200009	42	Reduction Plate	210142
10	Circlip	200010	43	Washer (6)	210043
11	Ball	200011	44	Planet Gear (3)	210144
12	Spindle	211012	45	Reduction Plate	210145
13	Needle Bearing	200013	46	Planet Gear (3)	210146
14	Circlip	211014	47	Main Gear	210147
15	Spring	211015	50	Motor Head	210050
16	Ring	211016	51	Motor	210351
17	Buffer Cone	211017	52	Carbon Brush Spring	210052
18	Hook Piece	211018	53	Carbon Brush	210053
19	Screw	201019	54	Black Housing Right	210154/ESD
20	Ring	210020	55	Start Lever	211255/ESD
21	Bearing	210021	56	Micro Switch	201056
22	Balls	210022	57	Reverse Switch	200057
23	Bearing Seat	210023	58	Black Housing Left	210158/ESD
24	Bearing Balls Seat	210024	59	Screw	210059
25	Ball	210025	60	Hook	200060
26	Fixed Clutch	210026	61	Spring	211061
27	Balls	210027	62	Isolator	Not used
28	Bearing	210028	63	Cable	200063
29	Oil Protector	210029	64	With code 200063	
30	Locking Nut	211030	65	Motor Locking Screw	210065
32	Clutch Housing	211032	66	5 Pin Connector	201666
33	Spring	200033	68	M3 Screw (2)	210068

1. Applications

KOLVER electric screwdrivers are used to tighten to the required torque screws, nuts, studs and any other kind of threaded connection on any material. Obviously, it is possible to use the screwdrivers with screw having a larger diameter if the torque fall within the indicated range. All models are reversible and can consequently be used to unscrew. Electric screwdrivers are mainly used in the electronic industry as well as for electric appliances, wiring, toys, lamps, glasses, in the mechanical light industry etc.

2. Use

KOLVER screwdriving system is composed by a screwdriver, a cable with 2 x M12 female 5 pin connectors and a power supply and control unit. To install it please follow the instructions.

- a) Connect the 5-pin connectors of the cable to the controller and to the screwdriver and tighten the relevant nuts.
- b) Connect the controller plug to a mains supply socket 90 / 230V- 50/60Hz.
- c) Switch the controller on through the black button on the back panel.
- d) Select the desired setting of speed (A) and slow start (R) options through the relevant knobs. Please make sure that such settings are compatible with the torque setting. Since the speed reduction is obtained through a voltage reduction (= power reduction), if the torque setting is too high for a low speed setting, the clutch may not operate correctly and get stuck. In such a case, the driver will not run and when you press the start lever the red light will signal. To reset the driver just turn the bit chuck until you hear the clutch “click” (usually 180°). Increase the speed setting before running the driver again.
- e) Similarly, the slow start setting should be chosen according to the torque that must be reached at full speed and not when the slow start is still in action.
- g) Do not slide the forward/reverse while the motor is running, it's dangerous for the motor.

3. Adjusting the torque

The torque value of the screwdriver is adjusted by changing the tension of the clutch spring, screwing or unscrewing the threaded #2 nut. After each adjustment lock the nut by means of #30 ring.

To increase the torque turn the nut clockwise, to decrease it turn the nut anticlockwise.

The tool is equipped with an extra spring to reach the lower torque values. To change the spring remove #2 nut, replace the spring and then adjust the torque value as mentioned above.

To check the torque value we suggest the use of K5 electronic torque tester.

4. Control unit and power supply

EDU 1FR power supply and control units act as voltage transformer and electronic torque controller.

The power supply, 90/260VAC-50/60Hz, is converted into 18-30V DC required by FAB and RAF series screwdrivers through an electronic transformer with constant power of 120W. The electronic control circuit cuts the power supply to the motor in response to the clutch action as soon as the pre-set torque has been reached.

On the front panel of the controller, there are two knobs indicated with the letters "R" and "A".

Knob "R" is used to adjust the slow start option (ramp) from 0 to 2 seconds, i.e. the motor will reach the nominal speed gradually. Dial "1" for no ramp and "10" for maximum ramp.

Knob "A" is used to adjust the motor speed for nominal speed, i.e. speed as per ctg. data sheet, to 60% of nominal speed. Dial "1" for minimum speed and "10" for nominal speed.

On the front panel you can also see 2 lights: the green one will light permanently when the power is on, the red one will light only when the clutch "fires" indicating the preset torque has been reached.

The temperature of the unit can normally reach 45°C.

EDU1FR/SG can be used with any Kolver screwdriver with clutch, either lever or push start, inline or pistol type.

This model rear panel presents one input connector to start/reverse motor rotation (trough contact), and one output connector for torque and pressed lever signal (24V 100mA). See the enclosure.

On the back panel you can find a socket equipped with a fuse holder and on/off switch. To replace the fuse just pull out the fuse holder and change the fuse.

Always remember to switch off the control unit at the end of each working shift.

5. Maintenance

The screwdriver's motor is equipped with carbon brushes 9mm long. When their length is about 5mm it is time to replace them as per the following instructions:

- a. Remove the #59 and #68 screws and the #54 and #58 housings.
- b. Remove #53 brushes from their seat by delicately lifting up the #52 spring and desolder their wire.
- c. Solder the wire of the new brushes, insert them into their seat and stop them with the relevant #52 springs.
- d. Re-mount the housing.

NOTE

The sound level generated by Kolver electric screwdrivers is always lower than 70dB(A).

The vibrations transmitted to operator's hand are lower than 2.5m/s². In particular the exposition to vibrations is lower than 1m/s² for operators who make up to 4200 screwing cycles per day.

WARRANTY

KOLVER warrants its products for a period of one year from the date of original purchase. Any products which examination proves to be defective in workmanship on material will be repaired or replaced free of charge during the warranty period. For repair or replacement return the product, transportation prepaid, to your nearest KOLVER service center. This warranty does not repair or replacement required as a consequence of misuse, abuse, normal wear and tear.